

KENWOOD

KAX720PL

instructions

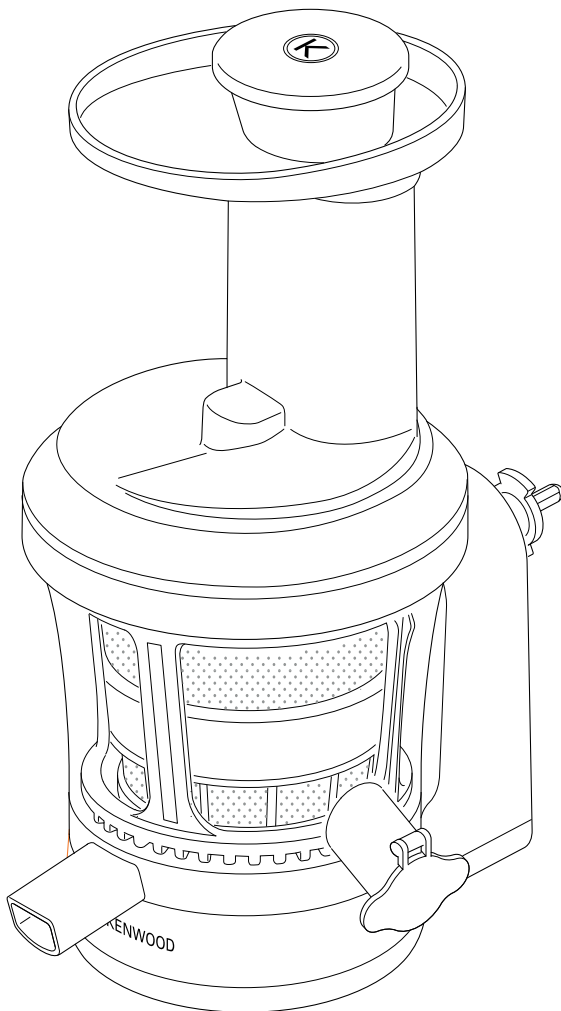
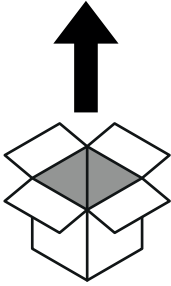
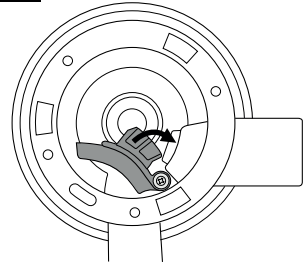
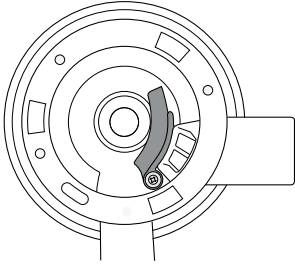
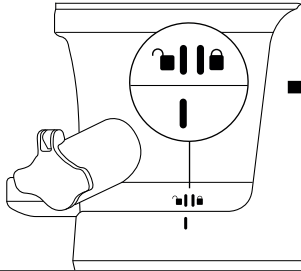
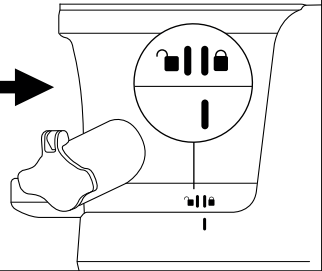
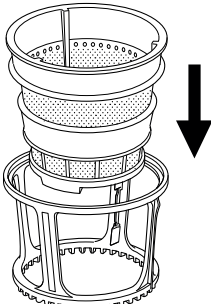
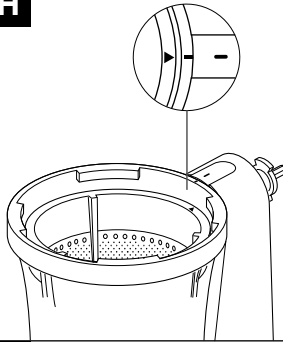
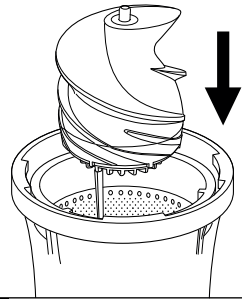
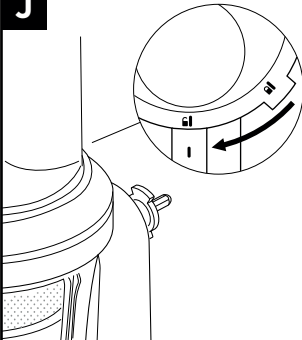
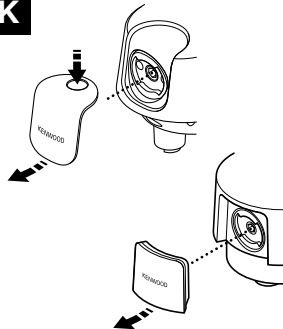
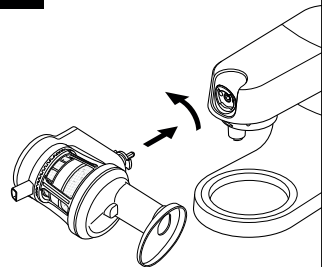

A**B****C****D****E****F****G****H****I****J****K****L**

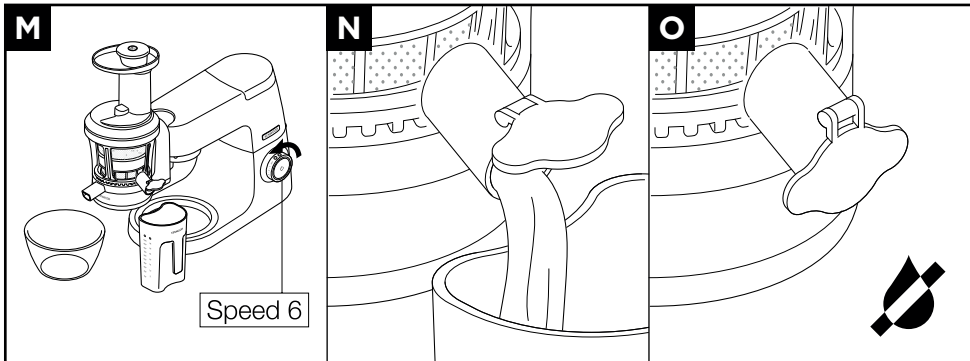

Safety

- Read these instructions carefully and retain for future reference.
- Before using for the first time, remove all packaging and any labels. Wash the parts: see 'Cleaning'.
- **Do not use the juicer if the filter is damaged.**
- Turn the speed control to 'O' OFF position and unplug:
 - before fitting or removing parts
 - before cleaning
 - after use.
- Never use a damaged attachment. Get it checked or repaired: see 'service and customer care'.
- **Only use the pusher supplied. Never put your fingers in the feed tube. Unplug and remove the lid before unblocking the feed tube.**
- Before removing the lid, switch off, wait for the filter to stop and remove the whole attachment from the outlet of the Stand Mixer.
- Do not over fill the feed tube or use excessive force to push the food down the feed tube – you could damage your attachment.
- Do not process frozen fruit or vegetables. Allow to defrost before processing.
- Do not process dried or hard ingredients such as grains, fruit with hard seeds or ice as they may damage the attachment.
- Do not touch moving parts.
- Never leave the attachment switched on unattended.
- Never use an unauthorised attachment, or more than one attachment at once.
- Misuse of your attachment can result in injury.
- Do not operate your appliance near the edge, or overhanging the work surface or apply force to the attachment when fitted, as this may cause the unit to become unstable and tip over, which may result in injury.

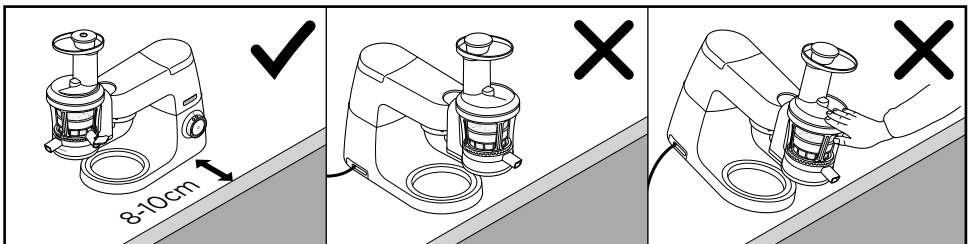

- Do not move or raise the mixer head with an attachment fitted as the Stand Mixer could become unstable.
- Children should be supervised to ensure that they do not play with the appliance.
- Appliances can be used by persons with reduced physical, sensory or mental capabilities or lack of experience and knowledge if they have been given supervision or instruction concerning use of the appliance in a safe way and if they understand the hazards involved.

- Only use the appliance for its intended domestic use. Kenwood will not accept any liability if the appliance is subject to improper use, or failure to comply with these instructions.

Refer to your main Stand Mixer instruction book for additional safety warnings.

Cleaning

- Drive unit - Wipe with a damp cloth, then dry. Do not immerse in water.
- Do not clean the pulp or filter outlet with a sharp pointed object such as the end of a knife as you will damage the bowl. Use the tip of the cleaning brush handle to clean the outlets.
- Use the brush supplied to clean the filter. For best results, rinse under water and brush until clear.

● This appliance conforms to EC Regulation 1935/2004 on materials and articles intended to come into contact with food.

This attachment features the Twist Connection System  and is designed to fit directly on the latest generation Kenwood Chef models (identified as TYPE KVC, KVL, KCC, KWL and KCL).

This attachment can also fit KMix Stand Mixers featuring a slow speed attachment outlet (TYPE KMX).

To check that this attachment is compatible with your Stand Mixer you will need to ensure both components feature the Twist Connection System .

If your Stand Mixer features the Bar Connection System  you will also need an adaptor before operation is possible. The reference code for the adaptor is KAT001ME. For more information and how to order the adaptor visit www.kenwoodworld.com.

Before using for the first time

Wash the parts: see 'Care and Cleaning'.

Key

- ① Pusher
- ② Lid with hopper
- ③ Scroll
- ④ Filter basket
- ⑤ Rotating wiper holder
- ⑥ Juicing bowl
- ⑦ Pulp spout
- ⑧ Juice spout

- ⑨ Anti-drip stopper
- ⑩ Drive shaft
- ⑪ Drive unit
- ⑫ Juice jug
- ⑬ Cleaning brush
- ⑭ Spanner





To Assemble your Juicer

Refer to Illustrations C - J

C - D

Fit the pulp stopper into the opening on the underside of the juicing bowl ⑥ and push in until secure.



E - F

Fit the juicing bowl ⑥ to the drive unit by aligning the  on the side of the bowl with the  on the drive unit. To lock the bowl on turn it clockwise until the  line up with the  on the drive unit.

G

Place the filter basket ④ into the wiper holder ⑤.





H

Lower the wiper holder assembly into the juicing bowl and align the  with the  on the top of the drive unit. Ensure that the filter basket is locked into place.

I

Place the scroll ③ into the filter basket and push down to secure. **Note: the lid cannot be fitted if the scroll is not fully pushed down.**

J

Fit the lid ② onto the unit ensuring the  lines up with the  on top of the drive unit. Then turn the lid clockwise until it clicks into place and the  lines up with the  on top of the drive unit. Place the food pusher ① into the feed tube.

To Use your Juicer

Refer to Illustrations **K** - **N**

K

Lift off the slow speed outlet cover.

L

With the attachment in the position shown locate to the slow speed outlet and rotate to lock into place.

M - N

Place a bowl under the pulp spout ⑦ and place the juice jug ⑫ under the juice spout ⑧. Ensure the anti-drip stopper ⑨ is in the open position before juicing.

- Use the recommended usage chart as a guide for juicing different fruits and vegetables.
Switch to speed 6 on your Stand Mixer and feed the food items down slowly using the pusher until processed. Note: The wiper holder is designed to rotate during operation.
- To extract the maximum amount of juice, always push the food down slowly using the pusher. Do not use excessive force as the food should be pulled down by the scroll. After adding the last piece of food, allow the juicer to run to help clear the juice from the juicing bowl. The time will vary depending on the fruit type and thickness of the juice extracted.

O

Switch off and wait until the final flow of juice has reduced to a few slow drips. Then place the anti-drip stopper ⑨ in position before removing the jug.

Refer to the troubleshooting section if you experience any problems with the operation of the attachment.

Clutch operation

There is an internal clutch designed to protect the attachment in the event that it becomes jammed. An occasional “clicking” sound in use is normal operation, however if food becomes jammed in the feed tube or scroll and the juicer stops operating, which results in a continual “clicking” sound, switch off the Stand Mixer and remove the attachment.

- Once the attachment is removed from the Stand Mixer, remove the lid and clear the blockage. If the lid is jammed and difficult to remove, use the spanner ⑭ provided to turn the attachment drive shaft in an anti-clockwise direction until the food becomes dislodged and the lid can be removed. Once the food is released re-assemble the attachment and re-fit to the Stand Mixer.

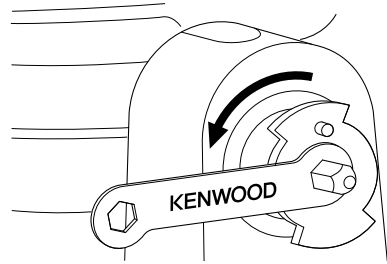

















Juicer Hints and Tips

- Wash all fruit and vegetable thoroughly before juicing.
- To maximise juice extraction place small quantities at a time in the feed tube and push down slowly.
- Hard foods are best juiced at room temperature.
- You do not have to remove thin peels or skins. Only remove thick peels that you would not eat e.g. those of oranges, pineapples, melons and uncooked beetroots.
- Use fresh fruit and vegetables as they contain more juice.
- Remove stones and hard seeds from cherries, plums etc.
- Vitamins disappear - the sooner you drink your juice, the more vitamins you will get.
- If you need to store the juice for a few hours put it in the fridge. It will keep better if you add a few drops of lemon juice.

Health Recommendations

- Do not drink more than three 230mls (8 fl.oz.) glasses of juice a day unless you are used to it.
- Dilute juice for children with an equal amount of water.
- Juice from dark green (broccoli, spinach etc.) or dark red (beetroot, red cabbage etc.) vegetables is extremely strong, so always dilute it.
- Fruit juice is high in Fructose (fruit sugar), so people with diabetes or low blood sugar should avoid drinking too much.

Recommended usage chart

Fruit/Vegetable	Preparation	Hints and Tips
	Cut down to fit the feed tube.	To maximise juice extraction hard foods are best juiced when at room temperature.
	Cut down to fit the feed tube.	
	Remove the leaves and stalks by slicing off the top and base. Cut into lengthwise pieces.	To prevent the filter from clogging clean the filter after every large pineapple.
	Remove stalks.	Process small handfuls at a time to maximise juice extraction.
	Cut down to fit the feed tube.	A thick pulpy juice will be produced rather than a smooth juice.
	Remove tough skin and stones.	The juice produced will be very thick.
	Remove tough skin.	-
	Cut down to fit the feed tube.	-
	Juice whole.	Process small handfuls at a time to maximise juice extraction.
		
	Remove leaves and peel.	-
	Wrap leaves into a bunch.	-
	Juice whole.	-
	Cut down to fit the feed tube.	-
	Peel and remove white pith.	-
	Remove the stones or hard seeds before juicing.	-
	Open the fruit by scoring the outside skin and breaking apart. Submerge in a large bowl of cold water and remove the seeds from the pulp (this helps to separate the seeds as they will sink to the bottom of the bowl and the white pulp will float to the top).	-

Care and Cleaning

Refer to Illustration

- Always switch off, unplug and take the juicer apart before cleaning.
- Some discolouration of parts may occur upon using ingredients such as carrot or leafy vegetables.
Cleaning all parts immediately after each use will help to reduce stains.
- Do not clean the pulp or filter outlet with a sharp pointed object such as the end of a knife as you will damage the bowl. Use the tip of the cleaning brush handle to clean the outlets.

Drive unit

- Wipe with a damp cloth, then dry.
- Do not immerse in water.

Filter

- To assist with removal of pulp and fibres, place the anti-drip stopper in the closed position. Switch the juicer on and pour approximately 300mls water down the feed tube. Operate the juicer for approximately 20 seconds, place the juice jug under the juice spout and open the stopper to allow the water to flow out.
- Always clean the filter basket immediately after juicing.
- Use the brush supplied to clean the filter.
For best results, rinse under water and brush until clear.

Wiper holder

- The wipers in the filter holder can be removed for cleaning. To assemble, Insert the upper/lower wipers into the gap of the filter holder and secure. Ensure that the wipers are replaced and fitted correctly before assembling the juicer.

Service and Customer Care

UK only

If you need help with:

- using your attachment
- servicing or repairs (in or out of guarantee)

 call Kenwood customer care on **0345 222 0458**. Have your model number (**KAX720PL**) and date code (e.g. **23B08**) ready. They are on the attachment outer carton.

● spares and attachments

 call 0844 557 3653.

other countries

- If you experience any problems with the operation of your attachment, before requesting assistance refer to the "Troubleshooting guide" section in the manual or visit www.kenwoodworld.com.
- Please note that your product is covered by a warranty, which complies with all legal provisions concerning any existing warranty and consumer rights in the country where the product was purchased.
- If your Kenwood product malfunctions or you find any defects, please send it or bring it to an authorised KENWOOD Service Centre. To find up to date details of your nearest authorised KENWOOD Service centre visit www.kenwoodworld.com or the website specific to your Country.
- Designed and engineered by Kenwood in the UK.
- Made in China.

Troubleshooting Guide

Problem	Cause	Solution
The attachment will not start/does not operate.	<ul style="list-style-type: none"> No power. Juicing bowl not properly aligned on drive unit or lid not locked correctly. 	<ul style="list-style-type: none"> Make sure the appliance is plugged in. Check that all parts are fitted correctly.
The juicer has stopped during normal operation. Continual clicking sound heard, internal clutch activated.	<ul style="list-style-type: none"> Clogging in filter and scroll. Food not cut into small enough pieces. 	<ul style="list-style-type: none"> Do not attempt to open the lid by force. Switch off, unplug remove the attachment from the Stand Mixer. Remove the lid. Check if any clogging. Remove food if necessary and continue juicing.
	<ul style="list-style-type: none"> Juicer overloaded due to heavy load. 	<ul style="list-style-type: none"> Switch off, unplug remove the attachment from the Stand Mixer. Take the juicer apart. Clear and reassemble the juicer.
Juice is leaking from underneath the bowl.	<ul style="list-style-type: none"> Pulp stopper not fitted or has come loose during operation. 	<ul style="list-style-type: none"> Check that the pulp outlet stopper is fitted correctly.
Juice does not exit juicing outlet.	<ul style="list-style-type: none"> Anti-drip stopper closed. 	<ul style="list-style-type: none"> Remove stopper and allow juice to flow into juice container.
Too much pulp coming out in juice.	<ul style="list-style-type: none"> Filter or scroll clogging. Very fibrous fruit/vegetable being processed. 	<ul style="list-style-type: none"> Cut food, especially fibrous foods, into smaller pieces to avoid the fibres wrapping around the scroll.
Wiper holder not rotating.	<ul style="list-style-type: none"> Filter or scroll not located correctly. 	<ul style="list-style-type: none"> Check and ensure attachment assembled correctly.
There is a squeaking noise when juicing.	<ul style="list-style-type: none"> Friction between wiper holder and bowl. 	<ul style="list-style-type: none"> Normal operation. Do not operate the attachment empty.
Staining on juicing parts.	<ul style="list-style-type: none"> Natural colouring from food. 	<ul style="list-style-type: none"> Rubbing with a cloth dipped in vegetable oil will help to remove discolouring.

Kenwood Ltd

New Lane
Havant
Hampshire
PO9 2NH

kenwoodworld.com

© Copyright 2023 Kenwood Limited. All rights reserved



5720071698/1